

Customer Story

Up to 60 % cost savings thanks to smaller included angles

Sustainable use of forceArc® in locomotive production

IN A NUTSHELL

Advantages at a Glance

- / Fewer passes – reduced welding times
Up to 60 % savings on costs for wages, materials and power.
- / Minimised straightening work
Reduced heat input results in less distortion.
- / Preparatory and rework reduced
Less time and effort for edge preparation.
- / Changing processes cuts down on emissions
Thanks to shorter welding times and the forceArc® process

Up to 60 % cost savings thanks to smaller included angles

Sustainable use of forceArc® in locomotive production

Already today, more than 50 percent of the nearly 7 billion people on our planet live in cities. The FAO estimates that the total population will rise to some 9.2 billion by 2050. By then the share of urban residents will likely be more than 75 percent. These people will need to be provided with natural resources, energy, water and food, as well as having the waste streams (wastewater, trash) they produce – and associated manufacturing waste – recycled, in terms of a recycling management that is as closed-loop as possible. The need for machinery, steel construction, means of transport and the like that this entails is enormous. However, their construction means consuming the required, limited resources at an ever-accelerating rate, which makes handling these increasingly scarce goods in a sustainable, efficient and environmentally-friendly manner all the more important – especially in industrial manufacturing. Welding is one of the key technologies in this regard, because to a great extent it is decisive as to the quality, safety, economic efficiency and environmental compatibility in the production of metallic components.



/ The welding experts of Siemens and Erl, from left to right: Mr. Hohlneicher (Erl), Mssrs. Drechsler, Bohrsdorf, Penzenstadler, Beitingner and Springer (Siemens) as well as Mr. Erl (Erl).

Mündersbach, 14 June 2013. – Within the scope of the BlueEvolution sustainability initiative, EWM AG has developed welding processes that make cost, energy and resource-intensive welding processes significantly more efficient. This helps to prevent a negative environmental impact, or at least reduce it to a minimum, and thus achieve a more efficient, economical and sustainable production. An example of this is the high-performance welding process forceArc®.

Smarter welding with forceArc®

The demands placed on modern welding technology are increasing unabatedly – whether due to the expansion of materials with ever-growing performance capabilities, rising expectations with regard to the quality, speed and reproducibility of results or the increasing cost pressure to contend with international competition. For the welding specialists from Mündersbach, Germany, this means that it's not enough to determine characteristics and configurations for a welding process. Instead, it's a matter of developing new processes that are specifically adapted to the welding task. Drawing on their core expertise in the areas of electronics, microprocessor technology and inverter technology, the engineers and technicians at EWM analysed the complex interactivity between the individual components and parameters and consequently optimised the entire welding process – thus breaking the code of welding. One of the high-performance welding processes that resulted is forceArc®. Its characteristic trait is a heat-minimising, directionally stable and powerful arc. The highly-dynamic current control also provides for a large penetration depth with fewer undercuts.

The most important advantages of forceArc® at a glance:

- / Material and labour cost savings
- / Lower electricity costs
- / Less preparatory and finishing work
- / Improvement of the working conditions by reducing welding fume emissions
- / Increased competitiveness and job security

Just how strong these advantages prove to be in practice depends on the mutual influence of many interdependent factors. For instance, the optimised material transfer and defined penetration depth under forceArc® enable weld geometries with smaller included angles. The most important target groups for forceArc® welding are the metal construction, mechanical engineering, equipment construction and plant engineering fields, as well as vehicle manufacturing, railway vehicle manufacturing and shipbuilding. This applies equally to both manual and mechanised or automated welding. Here is a practical example.



/ Perfect welding using forceArc® on a head piece for locomotives used for heavy-duty goods transport.

/ Efficient welding using forceArc® on a locomotive frame used for heavy-duty goods transport.





/ Nearly spatter-free seams ensure the utmost in quality. Consequently, this means welding consumables savings and significantly reduced post weld work.

High-performance welding in locomotive construction

In Siemens' locomotive manufacturing plant in the Allach quarter of Munich, locomotives have been produced for international markets for 170 years. The development, production and certification of locomotives made according to customer requirements are the core competencies of the company. For welding engineer Richard Beitinger, head of manufacturing at the Munich locomotive plant, the most important thing with regard to welding the different components and assemblies is maintaining the highest quality standards.

On the occasion of the DVS Expo in the Congress Center Hamburg (27–29 September 2011), Mr. Dieter Kocab, EWM welding expert, held a presentation on the topic of „New Types of Arcs – Perfect Welding Technology – a Glimpse of the Future“. This captured the interest of Siemens; an appointment was then arranged for the same month in which a presentation on innovative welding processes was to be made in Munich. Participants included managers from the construction design, welding supervision, work preparation and manufacturing departments. A visit to EWM by Siemens employees followed soon thereafter in December. The changed specifications and the adaptation of the weld preparation to the EWM processes for manual and mechanical welding were then discussed, as well as the requisite lab tests. Already on December 17, feedback came from Siemens that the results were positive and that as soon as early 2012 the welding of locomotives used for heavy-duty coal transport was to begin in Australia, utilising the technical state-of-the-art and EWM forceArc® process. The entire process conversion was accomplished in only 3 months. This is primarily thanks to the outstanding cooperation between

the Siemens team responsible for the process – consisting of design engineers, welding engineers, work planners and welders – and the EWM sales partner Erl-GmbH SCHWEISSEN + SCHNEIDEN, located in Landau, Germany. The determining factor for Siemens was that all components came from a single source and that with Erl they had an expert service partner close by.

After a year of practical experience now, the expectations placed upon this process have been fulfilled. Depending on the task at hand and the underlying materials, Siemens works with various joining processes. For black steel, it is either manual or robot-assisted MAG welding. The joining of aluminium or stainless steel parts, on the other hand, is accomplished using MIG or optionally TIG welding. When joining metal sheets with a wall thickness of about 15 mm or thicker, the welding specialists in Munich work with the forceArc® process and EWM power sources. Beitinger sees the advantages of the process conversion particularly in the significantly decreased welding distortion due to the substantially reduced heat input. Also positive are the very low effort necessary to prepare weld seams, the minimal number of welding passes required and the substantially shortened welding times. The latter not only makes it possible to more quickly manufacture components, it also gives the company more flexibility with regard to production and production planning.

In retrospect, Beitinger summarises: utilising innovative arc welding processes offers a great potential for savings at a low investment cost. Today, most manufacturers of welding power sources offer innovative arc technologies – but just switching to different characteristics alone is not enough. When implementing new welding processes,

focusing on the many details and thorough training of the welders is decisive. A further prerequisite for the quick and successful conversion of welding processes and welding construction design is that all key players are involved in the project right from the start – including a nearby, experienced system partner of the welding system manufacturer.

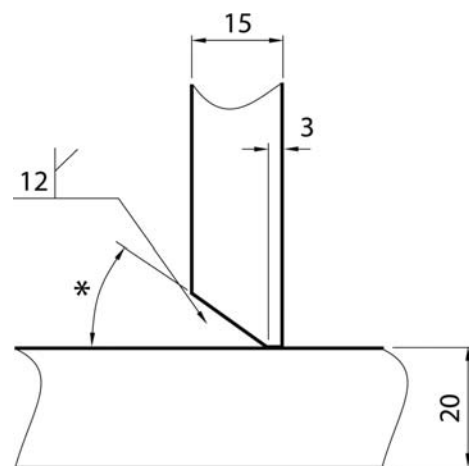

/ Thanks to a smaller included angle (*) of up to 30°, forceArc® reduces the weld volume by up to 60%, thus saving material, energy and working time.

Sale / Consultancy / Service